



A-1 ALCAZAR

Road Blocker

A-1 Alcazar Road Blocker

By BSP



ABOUT THE PRODUCT

Road Blockers have long been a mainstay in the perimeter security industry and are an indispensable tool in the Anti terrorism/Force Protection (AT/FP) toolbox for vehicular security. A-1 Fence Arabia has developed the most innovative crash rated wedge barrier to date that is precisely constructed to completely immobilize a large, high-speed vehicle for the utmost security against unwanted vehicle access. A-1 Alcazar Road Blocker is crash tested for **ASTM F2656-20 M50 P1** & compliant with **HCIS 2017 SEC-02** standard.

INNOVATIVE 3 FINGER DESIGN

Our 3 finger design requires no tracks, springs, pulleys, chains or internal electronics as this barrier can operate in any environment and is completely secured from tampering.

Because of its one-of-a-kind design, the A-1 Fence Arabia Wedge has the **least amount of above and below ground components** compared to any road blocker in the market.

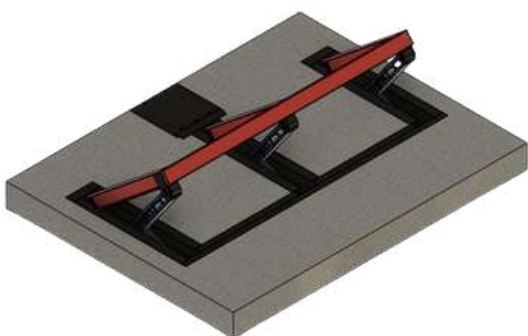

ASTM F2656 -20 M50 P1 CERTIFIED



Crash tested for stopping a vehicle of weight **6.8 tonnes** and moving with a velocity of **50 mph** with less than **1 meter penetration**

PRODUCT FEATURES



Easy Installation

Requires no rebar with easy drop and pour installation



Noiseless Operation

The flush ground design creates smooth passage for authorized vehicles



Shallow Foundation

Requires less civil work which in turn leads to cost saving



No Axle Load Limit

Any impact load is disbursed to the concrete foundation sustaining any vehicle load



Fast Operation

Emergency Operation speeds of less than 1.5 seconds



Easy Integration

Integrates with access control points over speed/wrong way detection



Light Frame Design

Allows for faster operation speeds and reduces wear on motor/actuator

TECHNICAL SPECIFICATIONS

PARAMETERS	SPECIFICATIONS
Blocking Width	10 to 18 feet
Blocking Height	42 inches (above ground)
Foundation Depth	18 inches (Min 4000 psi concrete)
Available Finishes	RAL 9005, RAL 3020
Optional Finishes	RAL 7021, RAL 1021
Security Rating	M50 P1 ASTM F2656-20
Impact Energy	1698.68 KJ, 6.8T @ 50mph
Normal Operation	3 -5 secs (Deploy/Retract)
Emergency Operation	Less than 1.5 secs (Deploy/Retract)
Temperature Range	-20 to +60 degree celsius
Cycling Time	6 to 8 complete cycle/ minute
Rated Pressure	max. 3000 Psi (200 bar)
Fluid Capacity	50 L

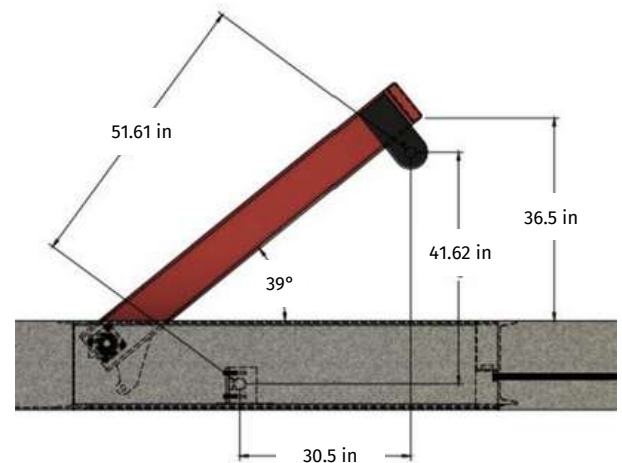

OPTIONAL FEATURES

- Customized Integrated Controls
- Visual and Audio Alarms
- Battery Backup System
- Heated and/or cooled foundation for extreme conditions



ABOUT **A-1 FENCE ARABIA**

A-1 Fence Arabia is a leading provider of innovative perimeter security solutions with over two decades of experience in the high security domain, making it a trusted provider of HCIS certified security solutions in Saudi Arabia. With our commitment to innovation and customer satisfaction, A-1 Fence Arabia is the best choice for your perimeter security needs.

